

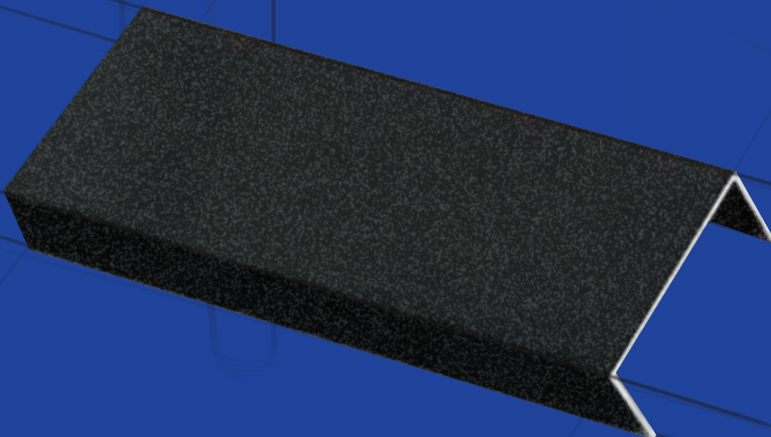

# HANDLES, KNOBS, DECORATIVE STRIP & EDGING

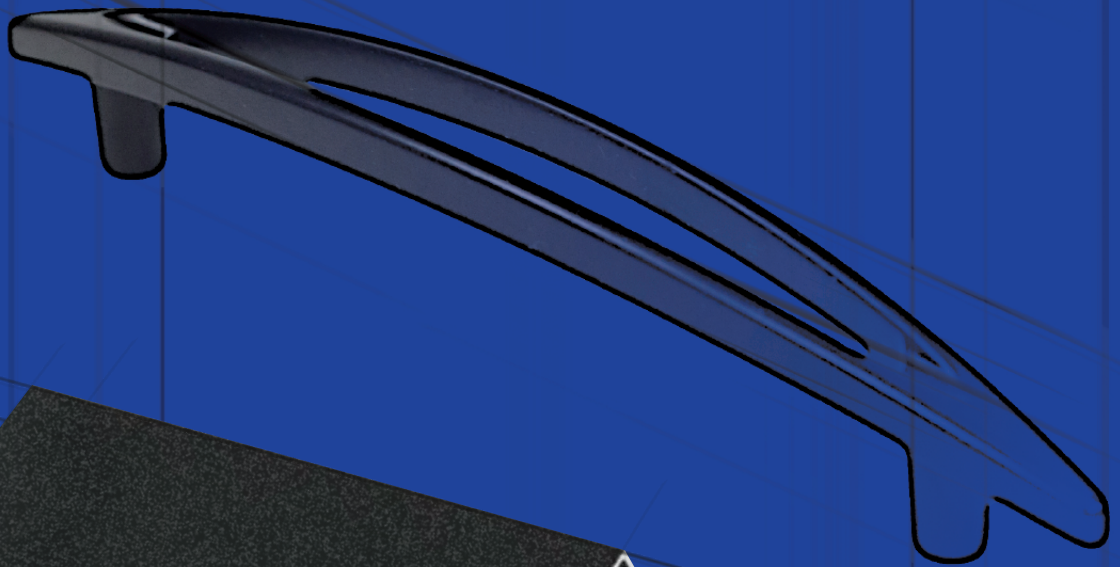
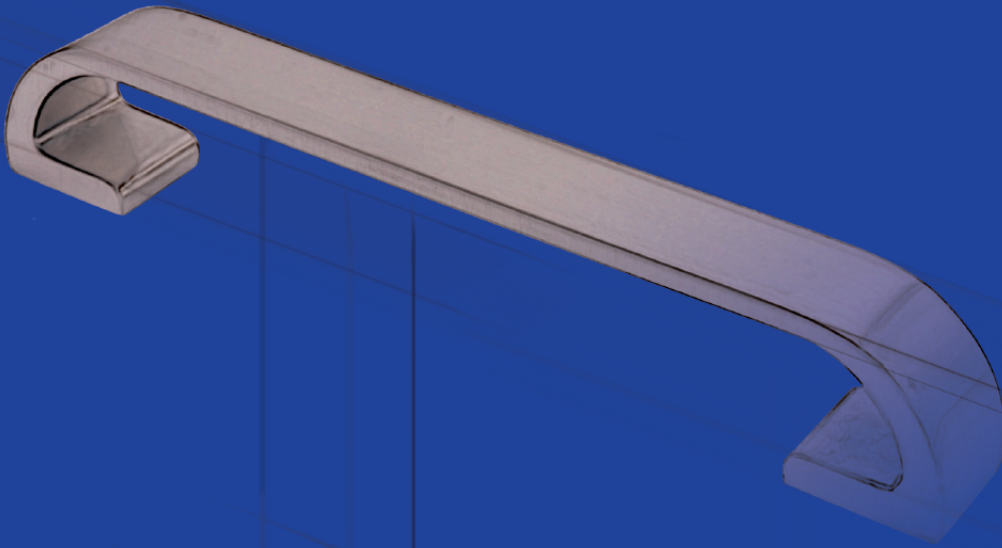

# List of Handle Finishing

Short Form	Full Name
AB	Antique Brushed
ABL	Antique Black
ABZ	Golden Black
AC	Antique Copper
AE	Antique English
AEG	Gloss Antique English
AL	Alum. Alloy
AP	Antique Pewter
ARG	Antique Rose Gold
ATC	Anthracite
BL	Black
BLM	Black Matt
BLR	Black Texture
BN	Brushed Nickel
BR	Brass
BRS	Brushed Brass Matt
CH	Chrome
CP	Champagne
CPR	Rustic Champagne
DAC	Dark Antique Copper
DAE	Dark Antique English

Short Form	Full Name
DT	Stainless Steel Chrome
GD	Gold
IVR	Ivory
LT	Synthetic Leather
MAB	Matt Brushed Antique
MN	Matt Nickel
MSR	Matt Nickel Hairline
MSS	Brush Nickel, Matt
NA	Natural Anodized
NK	Nickel Matt
ORB	Oil-Rub Bronze
RAE	Rustic Antique English
SC	Satin Chrome
SL	Silver Lacquer
SN	Satin Nickel
SS	Stainless Steel Finish
SSM	Stainless Steel Matt
WD	Natural Wood
WHBL	White Black
WHCH	White Chrome
ZN	Zinc Alloy

Material for most handle will be deemed to be Zinc Alloy unless otherwise specified.

Icons definition

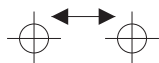

CC

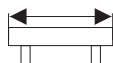

Length



Width

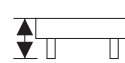

Height

# Handle Index

Item Code	Page	Item Code	Page	Item Code	Page	Item Code	Page	Item Code	Page	Item Code	Page
AL 317	20	HDL 289	4	HDL CH3	21	HDL D915	15	KN 496	37	SLDH D236	27
AL 440	22	HDL 289AL	4	HDL CH7	21	HDL D916	15	KN 497	40	SLDH D237	28
AL 530	22	HDL 290	4	HDL CH8	22	HDL D917	15	KN 498	34	SLDH D240	28
AL 536	22	HDL 295	8	HDL CH10	21	HDL D918	15	KN 631	32	SLDH D241	29
AN 538	21	HDL 296	5	HDL CH11	21	HDL D919	16	KN 634	38	SLDH D242	29
CN 822	42	HDL 297	8	HDL CH12	23	HDL D920	14	KN 650	32	SLDH D243	28
ES 8313	43	HDL 298	4	HDL CH13	23	KN 0030	31	KN 661	38	SLDH D821	43
ES 901	42	HDL 299	8	HDL CH14	23	KN 0033	32	KN 662	38	SRL YAL	43
HDL 0025	2	HDL 300	9	HDL CH15	24	KN 036	34	KN 672	39	PP CFU	43
HDL 0026	2	HDL 301	25	HDL CH16	24	KN 040	33	KN 675	39	PP CY	
HDL 0039	2	HDL 302	26	HDL CH19	24	KN 049	40	KN 678	39		
HDL 007	2	HDL 303	5	HDL D103	11	KN 089	36	KN 679	39		
HDL 100	2	HDL 306	5	HDL D135	11	KN 126	32	KN 728	38		
HDL 107	2	HDL 307	9	HDL D136	26	KN 127	32	KN 919	39		
HDL 112	7	HDL 309	10	HDL D137	11	KN 158	32	KN A320	36		
HDL 115	6	HDL 310	9	HDL D139	11	KN 2010	30	KN A351	35		
HDL 116	10	HDL 312	9	HDL D143	11	KN 2012	33	KN A362	35		
HDL 204	2	HDL 315	26	HDL D145	10	KN 2028	31	KN D313	36		
HDL 205	2	HDL 316	25	HDL D150	9	KN 243	40	KN D314	33		
HDL 206	2	HDL 318	9	HDL D151	11	KN 321	30	KN D315	36		
HDL 207	3	HDL 319	9	HDL D154	8	KN 40	33	KN D316	34		
HDL 208	3	HDL 320	9	HDL D170	14	KN 401	38	KN D317	35		
HDL 211	3	HDL 321	16	HDL D171	14	KN 410	37	KN D804	38		
HDL 212	6	HDL 323	9	HDL D172	11	KN 417	25	KN D806	39		
HDL 213	6	HDL 325	10	HDL D173	11	KN 423	35	KN D809	38		
HDL 214	7	HDL 326	9	HDL D174	11	KN 424	33	KN D810	39		
HDL 215	7	HDL 329	10	HDL D175	11	KN 425	35	KN D814	37		
HDL 217	3	HDL 334	12	HDL D176	12	KN 426	32	KN D816	38		
HDL 218	3	HDL 403	17	HDL D177	19	KN 428	35	KN D817	36		
HDL 222	3	HDL 404	17	HDL D178	12	KN 430	30	KN D818	35		
HDL 223	5	HDL 405	25	HDL D179	8	KN 431	34	KN D819	39		
HDL 224	5	HDL 406	18	HDL D180	12	KN 433	33	KN D820	37		
HDL 227	3	HDL 407	18	HDL D181	12	KN 442	32	KN D821	38		
HDL 229	7	HDL 409	18	HDL D182	29	KN 443	37	KN D822	38		
HDL 230	7	HDL 411	17	HDL D183	27	KN 447	39	KN D823	30		
HDL 232	7	HDL 412	20	HDL D184	12	KN 448	40	KN D824	36		
HDL 234	4	HDL 413	20	HDL D185	12	KN 449	40	KN D825	36		
HDL 236	7	HDL 416	20	HDL D186	12	KN 450	30	KN D826	30		
HDL 238	12	HDL 419	20	HDL D188	29	KN 453	40	KN D827	34		
HDL 239	7	HDL 436	17	HDL D189	13	KN 455	39	KN D828	33		
HDL 240	10	HDL 505	5	HDL D191	18	KN 458	35	KN F4025	4		
HDL 242	25	HDL 506	5	HDL D193	25	KN 459	31	KN P114	38		
HDL 247	25	HDL 506P	5	HDL D195	13	KN 460	31	P 8098	41		
HDL 249	7	HDL 603	14	HDL D196	13	KN 461	35	P 8110	40		
HDL 251	6	HDL 612	13	HDL D197	29	KN 462	34	P 8112	41		
HDL 253	12	HDL 613	14	HDL D198	29	KN 464	36	P 8117	41		
HDL 254	3	HDL 640	14	HDL D199	13	KN 465	34	P 8119	41		
HDL 255	8	HDL 673	29	HDL D200	19	KN 466	32	P 8223	42		
HDL 256	8	HDL 680	14	HDL D201	19	KN 468	37	P 8229	41		
HDL 257	8	HDL 683	10	HDL D202	13	KN 470	31	P 8230	41		
HDL 258	3	HDL 683A	10	HDL D203	13	KN 471	40	P 8246	41		
HDL 259	6	HDL 728	16	HDL D204	19	KN 472	31	P 8248	41		
HDL 262	3	HDL 743SAC	16	HDL D209	13	KN 473	31	P 8260	42		
HDL 264	6	HDL 832	28	HDL D210	26	KN 475	37	SLDH 024	27		
HDL 267	4	HDL 834	29	HDL D211	13	KN 476	31	SLDH 024A	27		
HDL 270	30	HDL 938	6	HDL D212	26	KN 477	31	SLDH 053	29		
HDL 271	6	HDL A116	10	HDL D213	26	KN 478	34	SLDH 055	27		
HDL 273	4	HDL A320	5	HDL D214	26	KN 483	33	SLDH 056	27		
HDL 275	4	HDL A341	7	HDL D239	27	KN 484	40	SLDH 058	30		
HDL 276	6	HDL A351	8	HDL D607	14	KN 485	32	SLDH 060	27		
HDL 279	25	HDL A362	8	HDL D610	14	KN 486	32	SLDH 062	30		
HDL 280	9	HDL A386	10	HDL D902	16	KN 487	38	SLDH 065	27		
HDL 281	25	HDL A394	10	HDL D906	14	KN 488	38	SLDH 066	28		
HDL 282	25	HDL A395	10	HDL D907	15	KN 489	32	SLDH 504B	28		
HDL 283	4	HDL A396	13	HDL D908	15	KN 490	31	SLDH A407	28		
HDL 284	6	HDL AS211	30	HDL D909	15	KN 491	33	SLDH A424	29		
HDL 286	25	HDL C026103	16	HDL D910	15	KN 492	37	SLDH A427	28		
HDL 287	4	HDL C205	2	HDL D912	15	KN 493	37	SLDH A428	29		
HDL 287E	4	HDL C216	16	HDL D913	16	KN 494	34	SLDH D201	27		
HDL 288	26	HDL C816	5	HDL D914	15	KN 495	35	SLDH D228	27		





● ● ● ● ●  
BL / CH / GD / SS

64	87	8.5	23	●
96	120	8.5	23	
128	154	8.5	23.5	



● ● ● ● ●  
BL / CH / GD / SS

64	82	8	30	●
96	118	8	30	



● ● ● ● ●  
CH / SN / SS

96	122	23	27	
----	-----	----	----	--



● ● ● ● ●  
BN / GD / SN / SS

96	120	8	25	
----	-----	---	----	--



● ● ● ● ●  
CH / SS

100	108	10	21	
-----	-----	----	----	--



● ● ● ● ●  
SC

96	122	15	27	
----	-----	----	----	--



● ● ● ● ● ● ● ● ● ● ●  
BL / CH / SC / MN / GD

96	115	11	28	
----	-----	----	----	--



● ● ● ● ● ● ● ● ● ● ●  
BN / MD / SN / SS / GD

128	143	13	26	
-----	-----	----	----	--



● ● ● ● ● ● ● ● ● ● ●  
CH / GD / SC / SL / SN

96	120	10	25	
128	160	10	25	



● ● ● ● ● ● ● ● ● ● ●  
CH / GD / SN

96	117	15	23	
----	-----	----	----	--

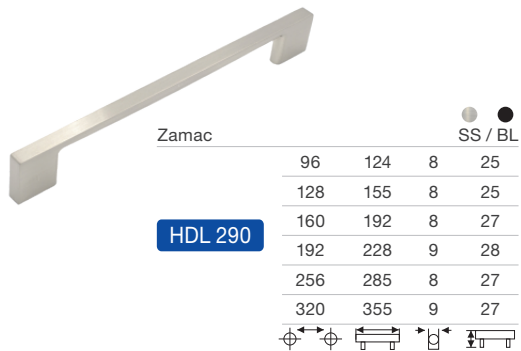
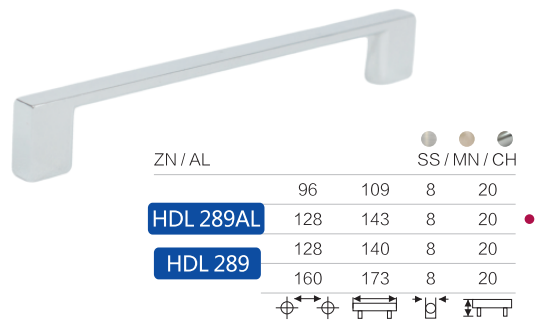
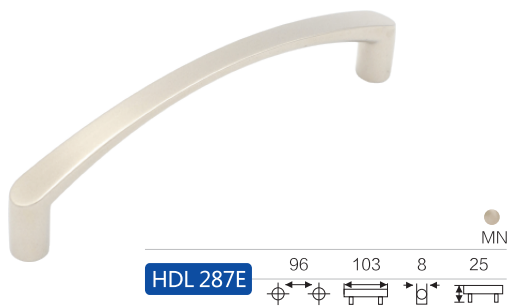
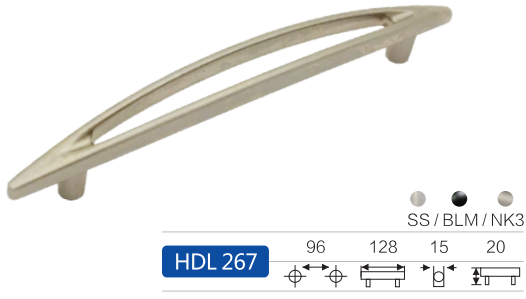



AE / SC / SL / AEG

	64	106	11	27
<b>HDL 303</b>	96	140	11	27
	128	178	11	27



BL / CH / SN / SS

	96	125	14	25
<b>HDL 306</b>				



BL / CH / SS

	128	145	8.5	25
<b>HDL 505</b>				



BL / CH / SN / SS / MN

	128	150	10	28
<b>HDL 506</b>	192	222	10	30
	224	270	10	26



CP

	96	110.5	10	10
<b>HDL 506P</b>				



SUS 201 BL / GD / SS

	128	140	12	35
	160	172	12	35
<b>HDL A320</b>	288	350	12	35
	384	396	12	35
	584	596	12	35



SS / BL

	96	125	16	20
<b>HDL C816</b>	128	157	16	23



SS

	32	89	13	20
	64	109	13	23
<b>HDL 296</b>	96	139	13	23
	128	169	13	25



AE / BL / CH / GD / SN

	32	49	17	19
<b>HDL 223</b>				



SC

	32	40	8	25
<b>HDL 224</b>				



●  
BN

<b>HDL 251</b>	60	28	15	78



● ●  
SC / SS

<b>HDL 259</b>	64	91	11	27



● ● ●  
SC / SN / SS

<b>HDL 264</b>	64	83.4	16.2	21



● ●  
BL / SC

<b>HDL 271</b>	39	49.7	12.5	19.7



●  
SL

<b>HDL 276</b>	64	77.2	6.5	23.7



●  
SS

<b>HDL 284</b>	64	73	11	25
	96	104	11	27
	128	138	12	28



● ● ● ● ● ● ●  
CH / SL / SC / SN / SS / BL

<b>HDL 938</b>	64	102	9	26
	96	143	9	26
	128	208	12	26



●  
SS

<b>HDL 115</b>	160	192	26	30



● ● ●  
CH / SN / SS

<b>HDL 212</b>	128	139	19	30



● ● ● ●  
AB / CH / SN / SS

<b>HDL 213</b>	128	150	13	27
	192	229	14	30



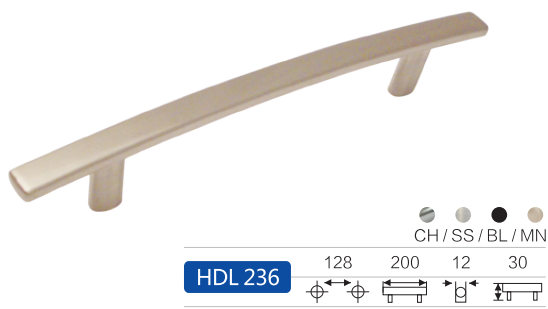
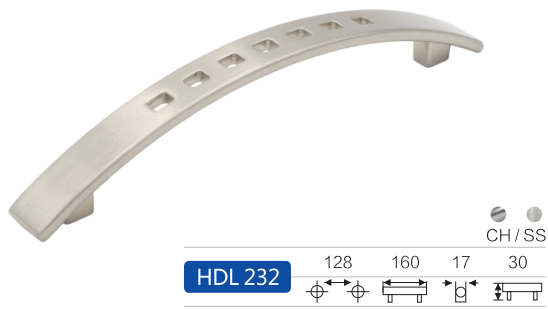
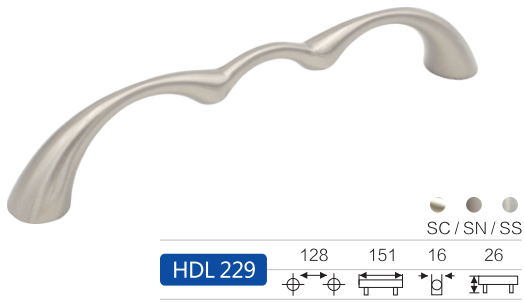
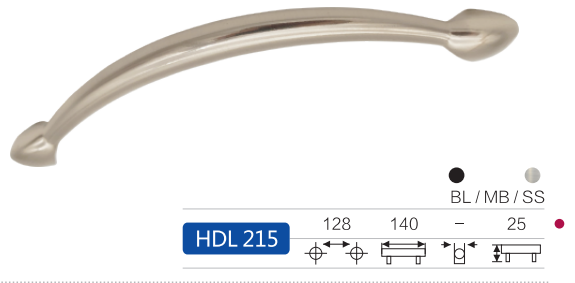



Zamac

**SUS 304**

SS

96	156	12	32	●
128	188	12	32	●
184	244	12	32	●
234	294	12	32	●
284	344	12	32	●
384	444	12	32	●

**HDL A351**



SUS201

GD / BL

96	150	12	32	●
128	200	12	32	●
160	250	12	32	●
256	400	12	32	●

**HDL A362**



SC / SS

128	138	10	29
-----	-----	----	----

**HDL 255**



SC

128	164	10	30
-----	-----	----	----

**HDL 256**



SC / SS

128	158	12	35
-----	-----	----	----

**HDL 257**



ZN / AL

SS

128	136.5	13.9	29
160	168.8	15	30

**HDL 295**



CH2

128	179.5	18.8	39.8
-----	-------	------	------

**HDL 297**



CH2 / SS

160	179.5	18.8	38.8
-----	-------	------	------

**HDL 299**



MN

96	140	17	26	●
128	175	17	26	●

**HDL D179**





AL + ZN

SS

200	250	12	60	●
-----	-----	----	----	---

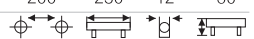
**HDL D154**



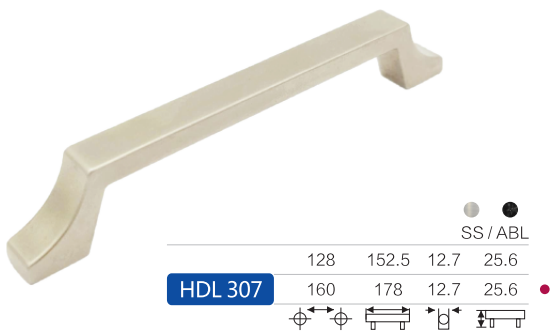
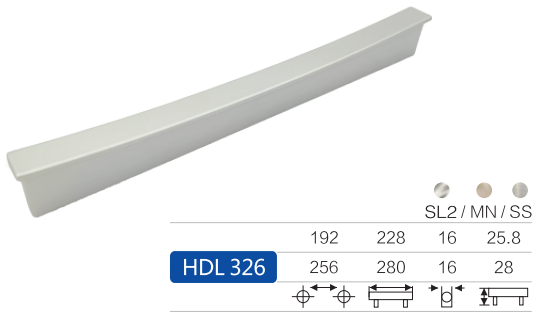
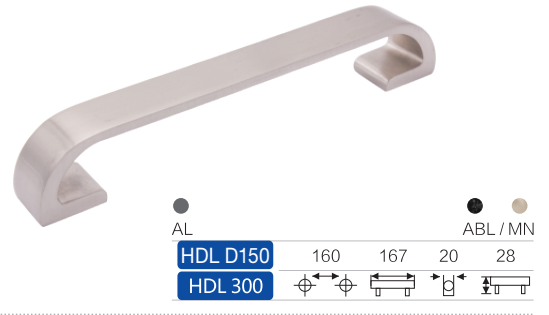

OLD COOE=HDL 113



SS / ABZ

<b>HDL D145</b>	160	207	15	30	●
<b>HDL 309</b>	⊕	⊕	⊕	⊕	⊕



SS

<b>HDL 325</b>	128	138	22	23	●
	160	170	25	26	●
	⊕	⊕	⊕	⊕	⊕

OLD COOE=HDL D137



SS

<b>HDL 329</b>	160	180	14	26	●
	⊕	⊕	⊕	⊕	⊕



ZN / AL SS

<b>HDL 683A</b>	128	142	15	24.5	●
<b>HDL 683</b>	160	178	18	18	●
	⊕	⊕	⊕	⊕	⊕



AL SS

<b>HDL A116</b>	160	184	14	26	●
	⊕	⊕	⊕	⊕	⊕

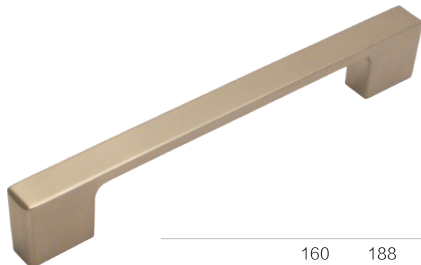

CP / SS

<b>HDL 116</b>	160	188	15	27.5	●
	256	282	14	28	●
	⊕	⊕	⊕	⊕	⊕



AL

<b>HDL 240</b>	160	171	24	24	●
	224	235	24	24	●
	⊕	⊕	⊕	⊕	⊕

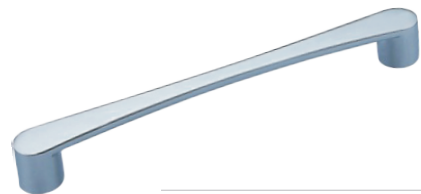

SS / BL

<b>HDL A386</b>	128	150	18	25	●
	160	185	18	25	●
	224	250	18	25	●
	⊕	⊕	⊕	⊕	⊕



SS

<b>HDL A394</b>	128	158	13	25	●
	160	191	13	25	●
	192	223	13	25	●
	⊕	⊕	⊕	⊕	⊕



SS

<b>HDL A395</b>	128	180	16	34	●
	160	210	16	34	●
	224	280	16	34	●
	⊕	⊕	⊕	⊕	⊕



● SS

128	144	10	34	●
160	174	10	34	●
192	207	10	34	●

**HDL D135**



● SL / CP

128	140	19	35	●
192	210	19	35	●

**HDL D103**



● AL

128	143	25	28	●
192	208	25	28	●
288	305	25	28	●



**HDL D139**

● AL

160	226	20	25	●
-----	-----	----	----	---

**HDL D143**

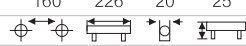
● AL

192	210	23	27	●
-----	-----	----	----	---

**HDL D151**

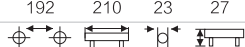

● SS / BL

128	140	21	25	●
-----	-----	----	----	---

**HDL D137**



● SS

128	164	15	27	●
192	245	15	27	●
256	307	15	27	●

**HDL D172**

● SS

192	246	23	24	●
320	374	23	24	●

**HDL D173**



● CH

192	234	17	34	●
-----	-----	----	----	---

**HDL D174**



● SS

128	141	15	25	●
192	240	13	25	●

**HDL D175**





● ●  
BL / SS

160	170	13	23
224	235	13	23
320	330	13	23

**HDL D176**



● ●  
ABZI / SS

153	165	25	27.5
-----	-----	----	------

**HDL 334**



●  
ATC

128	140	8	30
192	209	8	30

**HDL D181**



●  
ATC

128	138	12	30
192	202	12	30

**HDL D180**



Zamac ●  
BRS2

128	141	15	25
192	206	15	25

**HDL D186**

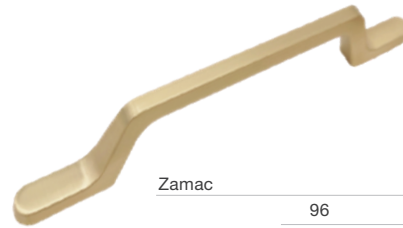

Zamac ● ●  
ATC / BRS2

96	12	25	
128	194	12	25
192	209	12	25

**HDL D178**

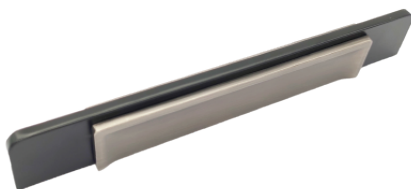

Zamac ● ●  
BLGD / GBL

16	48	10	22
64	150	10	22

**HDL D185**



Zamac ●  
BLGD

128	145	16	25
192	209	16	25

**HDL D184**



● ● ● ●  
BL / GD / SS / AE

128	160	32	39
-----	-----	----	----

**HDL 238**



● ●  
MN / RAE

96	130	30	25
----	-----	----	----

**HDL 253**



Zamac ● BL

HDL D189	96	130	20	24
	128	161	20	24



● BL

HDL A396	175	3050	25	20.5
----------	-----	------	----	------



● BL / BRS2

HDL D195	96	116	10	29
	128	148	10	29
	192	212	10	29



● BRS2

HDL D196	128	156	18	25
----------	-----	-----	----	----

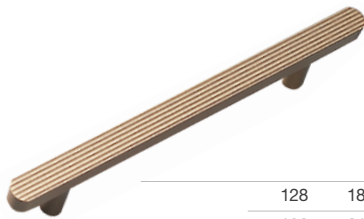

● BRS2

HDL D199	128	180	12	31
	160	215	12	31
	320	372	12	31
	512	600	12	31



● BRS2 / BL

HDL D202	23	2800	36	20
----------	----	------	----	----



● ATC

HDL D203	128	145	20	20
----------	-----	-----	----	----



● BL / SS

HDL D209	96	3050	73	20.5
----------	----	------	----	------



● BL / GD / SL

HDL D211	128	148	25	34
	160	180	25	34



● AB

HDL 612	76	105	50	-
---------	----	-----	----	---



AB  
 HDL 613 77 110 32 45



AE / SN  
 HDL 640 96 114 27 17



AB  
 HDL 680 100 132 60 -



WHBL  
 HDL D171 128 145 20 31



WHCH  
 HDL D170 128 138 20 35



IVR  
 HDL 603 96 146 42 -



AE  
 HDL D610 - 242 29 34



AE  
 HDL D607 128 224 - 17

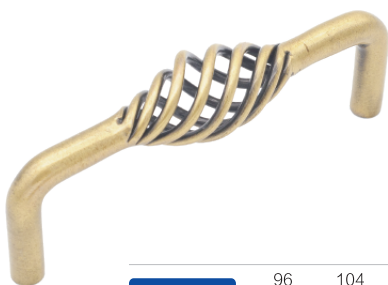

AE  
 HDL D906 96 104 18 40



ARG  
 HDL D920 128 166 22 23  
 192 232 22 23





● AE

<b>HDL D909</b>	96	118	29	20

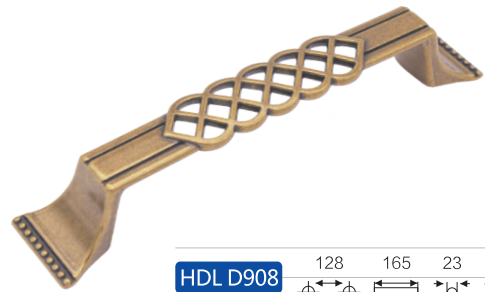

● AE

<b>HDL D908</b>	128	165	23	28



● AE

<b>HDL D912</b>	96	132	-	20



● AE

<b>HDL D910</b>	96	100	21	25



● MAB

<b>HDL D914</b>	96	150	16	25



● AE / AC

<b>HDL D907</b>	96	118	22	24



● MAB

<b>HDL D918</b>	96	135	25	23



● MAB

<b>HDL D916</b>	96	131	15	23



● ORB

<b>HDL D917</b>	128	148	20	23



● ORB

<b>HDL D915</b>	128	177	11.5	26

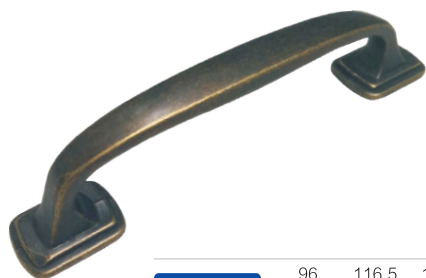

● AE  
**HDL 321** 96 116.5 18 25.5



● ORB  
**HDL D919** 128 154 23 31



● AE  
**HDL C026103** - 103 25 17



● AB  
**HDL 728** 64 88 32 28



● AE  
**HDL 743SAC** 100 141 26 23



● AE  
**HDL C216** 100 70 33 12

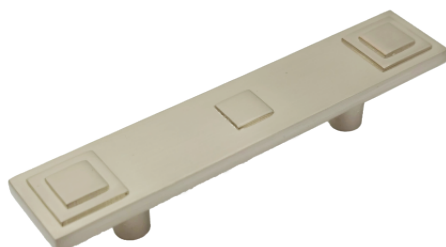

● SS  
**HDL D902** 64 110 22 19



● AE  
**HDL D913** 96 121 23 28

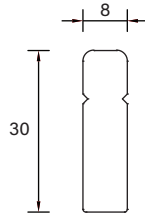

AL				BRL
	-	1080	8	30
<b>HDL 436</b>				

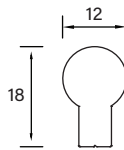

AL				SL
	32	52	12	18
	64	84	12	18
	96	116	12	18
<b>HDL 403</b>				
	128	148	12	18
	184	244	12	18
	234	294	12	18
	284	344	12	18
	334	394	12	18
Dimension (mm)				

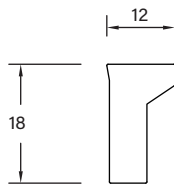

AL				SL
	32	52	12	18
	64	84	12	18
	96	116	12	18
<b>HDL 404</b>				
	128	148	12	18
	184	244	12	18
	234	294	12	18
	284	340	12	18
	334	394	12	18
Dimension (mm)				

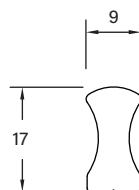

AL			SL / SC2
	32	52	9 17
	64	84	9 17
	96	116	9 17
<b>HDL 411</b>			
	128	148	9 17
	184	214	9 17
	234	254	9 17
	284	304	9 17
Dimension (mm)			

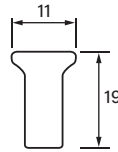

AL	● ● ● ● BL / BRS2				
	128	150	11	19	●
	160	180	11	19	●
<b>HDL D191</b>	192	220	11	19	●
	544	600	11	19	●
	960	1000	11	19	●
Dimension (mm)					



AL	● ● ● ● SL				
	96	109	16.5	36	
	128	141	16.5	36	
	160	173	16.5	36	
	192	205	16.5	36	
	234	247	16.5	36	
<b>HDL 409</b>	284	297	16.5	36	
	334	347	16.5	36	
	384	397	16.5	36	
	434	447	16.5	36	
	484	497	16.5	36	
	534	547	16.5	36	
Dimension (mm)					



AL + ZN	● ● ● ● SL				
	96	134	13	33	
	128	166	13	33	
	160	198	13	33	
<b>HDL 406</b>	192	230	13	33	
	224	262	13	33	
	256	294	13	33	
	320	358	13	33	
Dimension (mm)					



AL	● ● ● ● SL				
	96	109	13	33	
	128	141	13	33	
	160	173	13	33	
<b>HDL 407</b>	192	205	13	33	
	224	237	13	33	
	288	301	13	33	
Dimension (mm)					

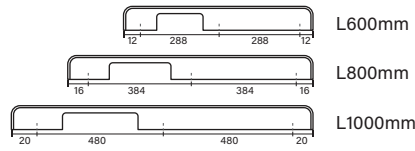

AL	BL / BRS2				
	128	150	9	28	●
	160	180	9	28	●
	192	210	9	28	●
	224	244	9	28	●
	320	340	9	28	●
3 holes	576	600	9	28	●
3 holes	768	800	9	28	●
3 holes	960	1000	9	28	●

**HDL D177**

Dimension (mm)

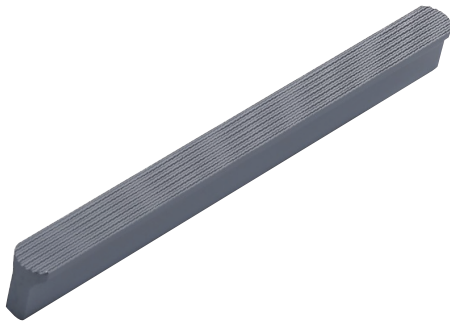

		ATC2		
	128	148	11	17
	192	210	11	17
	320	340	11	17
	3*	600	11	17
	3*	1000	11	17

**HDL D204**



		BLSL		
	128	150	11	18
	192	192	11	18
	320	340	11	18
	3*	600	11	18
	3*	1000	11	18

**HDL D201**

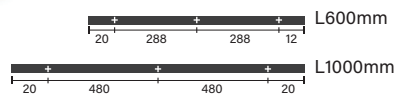

		BL / BRS2		
	128	150	11	40
	160	180	11	40
	192	210	11	40
	256	300	11	40
	320	340	11	40
2 holes	576	600	11	40
2 holes	960	1000	11	40

**HDL D200**

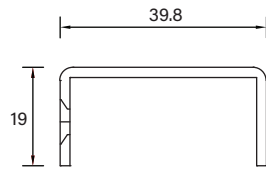
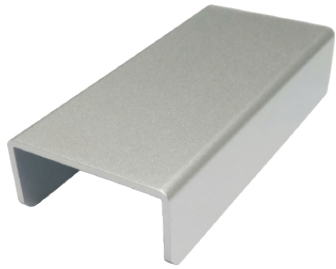

●	AL				●	SS
		256	296	39.8	19	
	<b>HDL 419</b>	516	556	39.8	19	

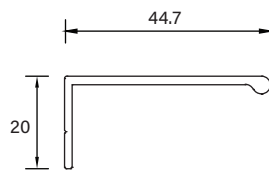
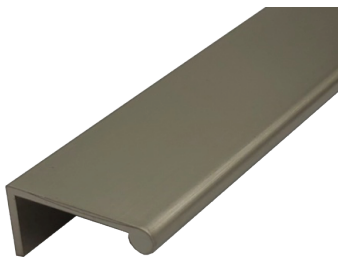

●	AL			●	BLM / SL2
		960	1083	44.7	20
	<b>HDL 413</b>				

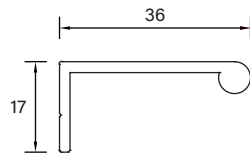

●	AL			●	GD4 / BLM
		24	40	36	17
		64	80	36	17
		96	120	36	17
		128	152	36	17
	<b>HDL 412</b>	168	200	36	17
		192	216	36	17
		224	248	36	17
		320	344	36	17
		960	1000	36	17

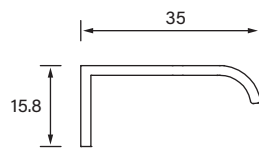

●	AL			●	SL / BM2
		24	38	35	16
		64	80	35	16
		96	120	35	16
		128	152	35	16
	<b>HDL 416</b>	160	184	35	16
		192	216	35	16
		224	248	35	16
		320	334	35	16
	Dimension (mm)				

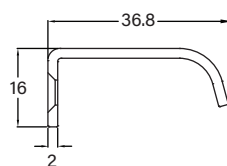
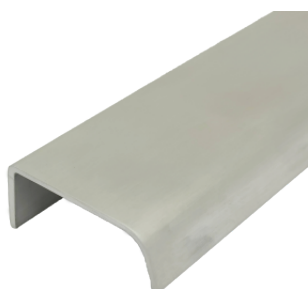

●	AL				●	MILL
		-	3050	36.5	15.5	
	<b>AL 317</b>					

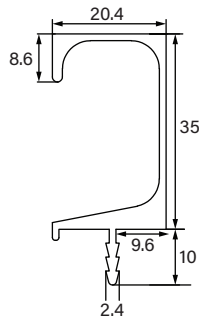

●  
AL

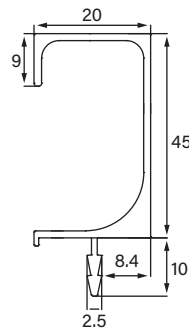

●  
AL

●  
NA

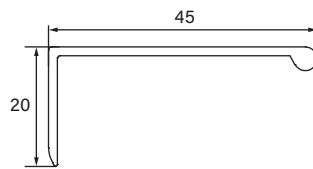
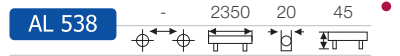

●  
AL

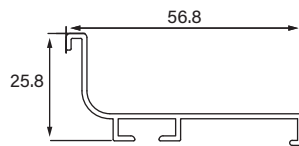
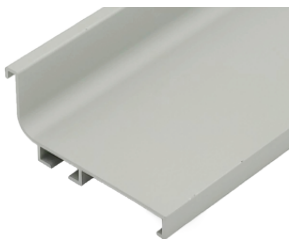

●  
AL

●  
SL / BL

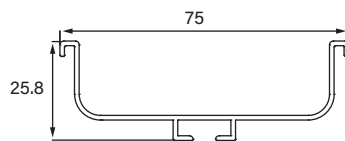
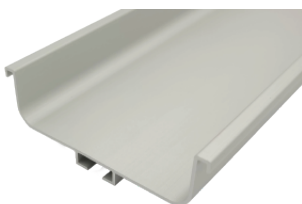
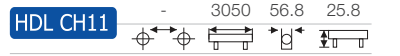

●  
AL

●  
SL / BL



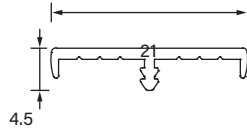

●	AL		●	NA / BLM2	●
	<b>AL 530</b>	-	5000	21	4.5

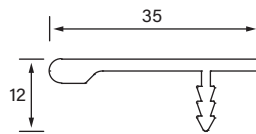
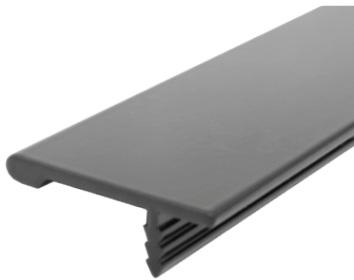

●	AL		●	BLM2	●
	<b>AL 536</b>	-	3500	35	12

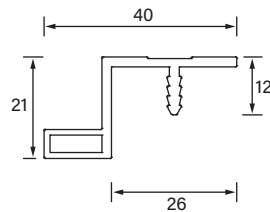

●	AL		●	BLM2	●
	<b>AL 440</b>	-	5300	40	21

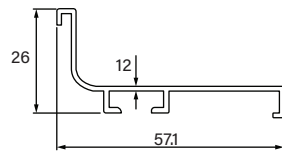

●	AL		●	SL / BL	●
	<b>HDL CH8</b>	-	3050	57.1	26



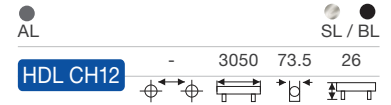
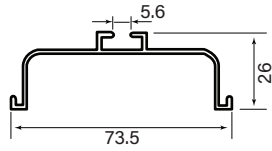

**END CAPS FOR U-SHAPE ALUMINIUM HANDLE**  
Finishing : Silver/Black

**HDL CH12.EC**



**L-BRACKET C/W SCREWS**  
Size: 47 x 47 x 12.5mm  
Material: Steel Plated

**ADF LB4747**

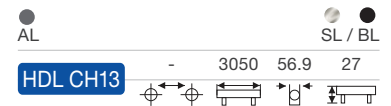
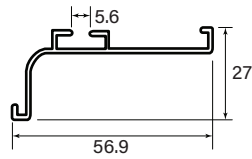

**END CAPS FOR J-SHAPE ALUMINIUM HANDLE**  
Finishing : Silver/Black

**HDL CH13.EC**



**L-BRACKET C/W SCREWS**  
Size: 47 x 47 x 12.5mm  
Material: Steel Plated

**ADF LB4747**

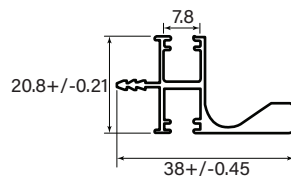

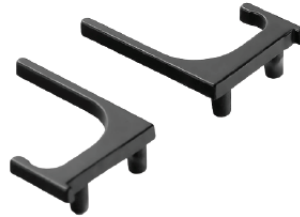

**LEFT RIGHT END CAPS FOR L-SHAPE ALUMINIUM HANDLE**

Size : 3M (10FT)  
Finishing : Black

**HDL CH19.EC.BL**

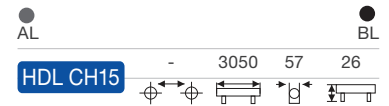
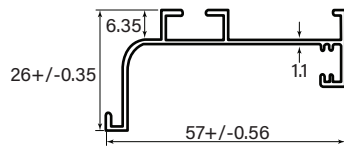

**END CAPS FOR U-SHAPE ALUMINIUM HANDLE**

Finishing : Silver/Black

**HDL CH12.EC**



**L-BRACKET C/W SCREWS**

Size: 47 x 47 x 12.5mm  
Material: Steel Plated

**ADF LB4747**

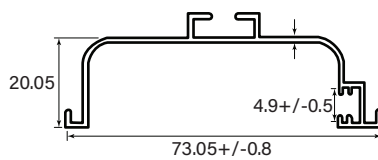

**100MM CORNER BRACKET FOR J-SHAPE ALUMINIUM HANDLE USE**

Finishing : Black

**HDL CH16.CB.BL**



**END CAPS FOR J-SHAPE ALUMINIUM HANDLE**

Finishing : Silver/Black

**HDL CH13.EC**



**L-BRACKET C/W SCREWS**

Size: 47 x 47 x 12.5mm  
Material: Steel Plated

**ADF LB4747**



● ● ●  
SS / BLM / SL

<b>HDL 242</b>	32	91	-	18
----------------	----	----	---	----



● ●  
SS / BLR

<b>KN 417</b>	32	51	-	16
---------------	----	----	---	----



● ●  
SS / BLR

<b>HDL 286</b>	64	150	-	21
----------------	----	-----	---	----



● ● ● ●  
SS / MN / BLR / MSR

<b>HDL 316</b>	32	86	21	26
	96	163	24.1	29
	128	178	24.5	17.5



●  
SS

<b>HDL 301</b>	-	188	144	45
----------------	---	-----	-----	----

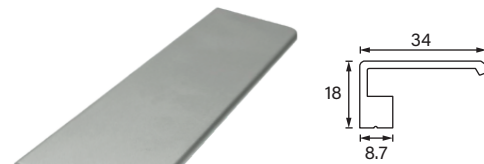

● ● ●  
SL / BL / BRS2

<b>HDL D193</b>	96	120	34	18
	128	150	34	18

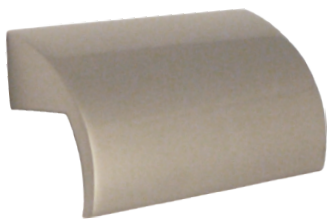

● ● ● ●  
MN / BL / SS / GD

<b>HDL 247</b>	64	80	20	35
----------------	----	----	----	----



● ● ●  
AL SC

<b>HDL 405</b>	64	90	24	22
----------------	----	----	----	----



●  
CH2

<b>HDL 279</b>	57	88	27	18
----------------	----	----	----	----



●  
CH

<b>HDL 281</b>	60	90	27	16
----------------	----	----	----	----



SS

<b>HDL 282</b>	64	80	39	26



MSS

<b>HDL 288</b>	89	108	38	21



NK2

<b>HDL 302</b>	76	111	14	32



SS

<b>HDL 315</b>	64	84	25	19.5



BL / BRS2

<b>HDL D210</b>	64	79	39	20



ATC / BL / BRS3

<b>HDL D212_LR/L</b>	-	200	30	12



ATC / BL / BRS3

<b>HDL D213_LR/L</b>	-	200	30	12



ATC / BL / BRS3

<b>HDL D214</b>	-	130	64	12



SS

<b>HDL D136</b>	96	115	37	20



Zamac SSM

<b>SLDH D237</b>	96	114	38	18



● SSM

	64	110	28	19	●
<b>HDL D183</b>	128	175	28	19	●



● SC

	96	105	129	T12	●
<b>SLDH 024</b>	128	137	28	17	●

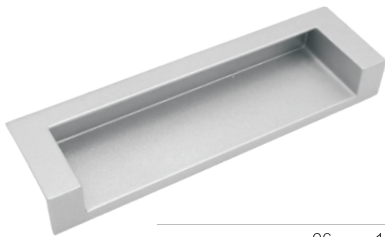

● SC / BL

	96	112	30	12	●
<b>SLDH 024A</b>	128	145	30	12	●



● SL

	-	400	38	20.5	●
<b>SLDH 055</b>					



● SS

	96	109	38	15	●
<b>SLDH 056</b>					



● CH

	128	140	38	13	●
<b>SLDH 060</b>					



● CP7

	-	132	38	13	●
<b>SLDH 065</b>					



● DT

	128	162	-	-	●
<b>SLDH D201</b>					



● AL + ZN DT

	96	106	42.2	18.6	●
<b>SLDH D228</b>	128	138	42.2	18.6	●



● SL

	96	112	42	25	●
<b>SLDH D236</b>	128	144	42	25	●



AE / SS

SLDH 066	-	110	40	12
----------	---	-----	----	----



AB / SS

SLDH 504B	96	105	41.5	12.5
-----------	----	-----	------	------



SUS304

SS / BL

SLDH A427	-	120	40	14
-----------	---	-----	----	----



SUS304

SS / BL

SLDH A407	-	150	50	14
-----------	---	-----	----	----



Zamac

GD

SLDH D238	80	170	40	19
-----------	----	-----	----	----



SS

SLDH D821	-	67	18	-
-----------	---	----	----	---



Zamac

ATC / BRS2

HDL D239	96	110	40	20
	96	110	40	20



SL / BL / SS / CH

HDL 832	32	54	48	14
	128	130	50	15

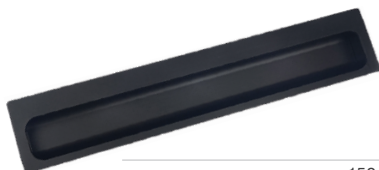

BL

SLDH D240	-	150	37	15
	-	200	37	15
	-	400	37	15
	-	600	37	15
	-	1000	37	15

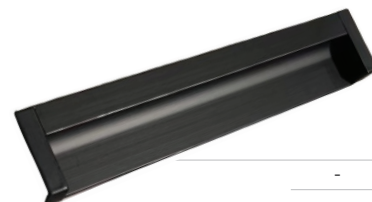

BL / ATC3 / GD

SLDH D241	-	120	30	17
	-	150	30	17
	-	300	30	17
	-	600	30	17
	-	800	30	17



● ● ●  
BL / ATC3 / WH

	32	73	26	15
<b>SLDH D242</b>	96	157	26	15



● ●  
ATC3 / WH

	32	72	25	14
<b>SLDH D243</b>	96	158	25	14



●  
SS

	-	180	60	15.5
<b>SLDH A428</b>				



Zamac

●  
ATC

	38	51	57	9
<b>HDL D188</b>	70	88	88	9



●  
AE

	32	77	45	10
<b>HDL 673</b>				



●  
ATC

	64	75	35	7
<b>HDL D182</b>				



● ●  
ATC / BRS2

	75	-	50	12
<b>HDL D197</b>				



● ● ●  
BL / ATC / BRS2

	75	64	40	8
<b>HDL D198</b>				



● ●  
SS / CH

	32	40	40	6
<b>HDL 834</b>	64	72	38	6

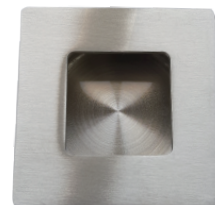

●  
SS

<b>SLDH 053</b>	4	46	-	13
<b>SLDH A424</b>	50	50	-	12



SUS304



ZN + SUS

**HDL AS211** 85 100 20.5 -



SSM

**SLDH 062**

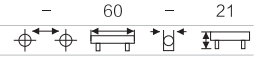

BLM

**SLDH 058**

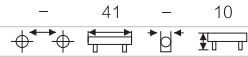

ATC / BRS2

**KN D823**

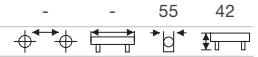

ATB2 / ACTH

**KN D826**



SC

**HDL 270**



CH / BL / SC / SN / SS

**KN 2010**

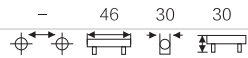

CH

**KN 430**

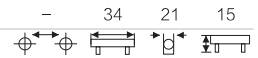

SC / MN

**KN 450**

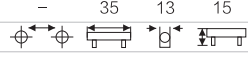

SC / SN / GD

**KN 321**

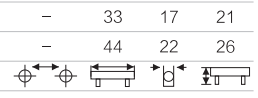







	CH / GD / MN / SC / SS / SN / BLM4		
	-	20	- 23
<b>KN 158</b>	-	25	- 23
	-	30	- 23



				AE
	-	31	-	21
<b>KN 650</b>				



			SS
	-	35	- 24.8
<b>KN 485</b>			



			SC
	-	22	- 21
<b>KN 426</b>			



			NK3
	-	13	13 11
<b>KN 466</b>			



				BN / CH / GD / SC
	-	35	-	35
<b>KN 127</b>				



			MN
	-	25	- 24
<b>KN 489</b>			



				BN / CH / GD / SS
	-	30	-	33
<b>KN 126</b>				



			SS
	-	30	- 27
<b>KN 486</b>			



				BR	BN / CH / GD
	-	25	-	23	
<b>KN 0033</b>					



● ● ● ● ● ● ●  
BN / CH / GD / BL / BLM / SS



●  
BRS2

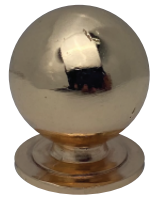
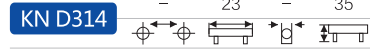

●  
GD

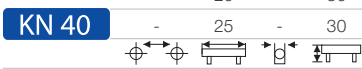

●  
BRS2

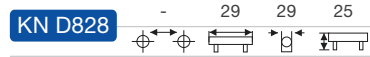

●  
SS

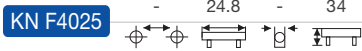

● ●  
SS / BLM

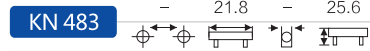

●  
SC

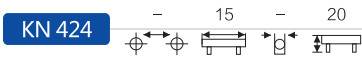

● ● ● ●  
SL / SN / CH / SS

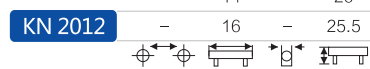

●  
SS



● ● ● ●  
BL / CH / SN / SS

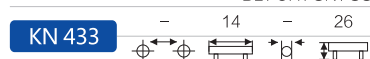

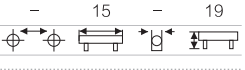

● CP1  
**KN 465** - 15 - 19  

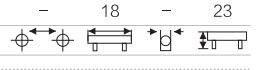

● ● ● ● SC / SN / CH / SS  
**KN 462** - 18 - 23  

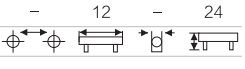

● MN  
**KN 634** - 12 - 24  

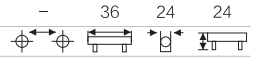

● GDCH  
**KN 036** - 36 24 24  

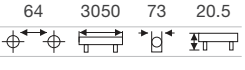

● SS  
**KN D827** 64 3050 73 20.5  

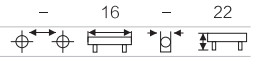

● ● SS / SC  
**KN 442** - 16 - 22  

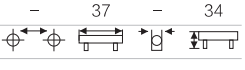

● ● SS / MN  
**KN 494** - 37 - 34  

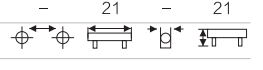

● SN6  
**KN 431** - 21 - 21  

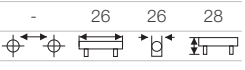

Zamac ● BRS2  
**KN D316** - 26 26 28 ●  

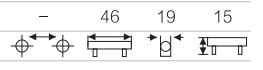

● CP2  
**KN 478** - 46 19 15  



● SN6

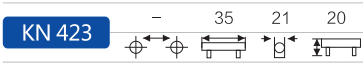

● MN



● CP1

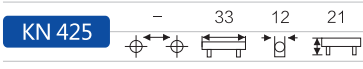

● SSM / BLM / DAE

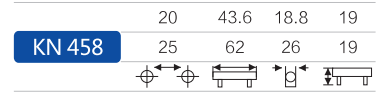

● SS



● MAB

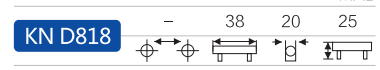

● SS

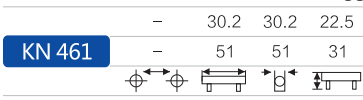

Zamac BRS2

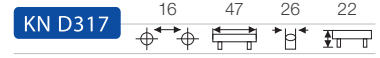

SUS201 ● BL / GD ●

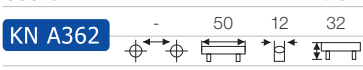

SUS304 ● SS ●

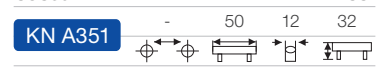



SUS201  
 BL / GD / SS  
 KN A320 - 50 12 35



ATC  
 KN D821 27 - 27 27



BL / BRS2 / SS / ATC  
 KN D822 - - 30 25



ATC / BRS2  
 KN D824 58 - 30 14



BRS2  
 KN D825 - - 34 22



BLGD  
 KN D315 - 38 24 26



ORB  
 KN D817 - 32 32 24



SS  
 KN 464 - 25 25 18



ATC  
 KN D313 32 - - 33



SS / SN / AE / BL  
 KN 089 - 25 - 23  
 - 32 - 23



● ●  
ABZI / SS

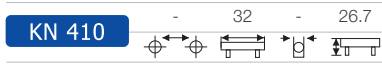

●  
ABZ



●  
NK3



●  
AE



● ●  
AC / AB



● ●  
ABL / SS



●  
ARG



●  
AE

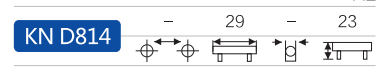

●  
AE

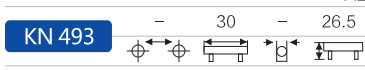

● ●  
AE / ABL

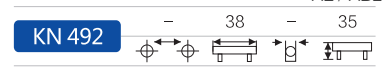

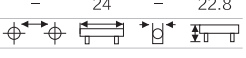

● BRS2  
 KN 401    -    24    -    22.8  

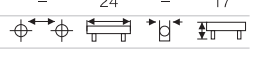

● AE  
 KN 728    -    24    -    17  

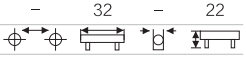

●  
 KN 488    -    32    -    22  



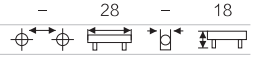

● AE  
 KN 487    -    28    -    18  





●  
 KN P114    -    38    -    27  





● AE  
 KN 662    -    22    -    17  



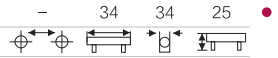

● AE  
 KN 661    -    41    -    21  





● AE  
 KN D809    -    34    34    25  



● MAB  
 KN D816    -    30    -    25  



● AE  
 KN D804    -    41    25    24  





● AE  
**KN D810** 32 72 30.5 20 ●



● AE  
**KN D806** - 50 12 40 ●



● ORB  
**KN D819** - 58 20 35 ●



● AE  
**KN 919** - 56 37 22 ●



● AC  
**KN 675** - 47 29 15



● AE  
**KN 679** - 46 66 17



● AB  
**KN 455** 32 60 48 15



● AE  
**KN 672** - 47 32 15



● ● ● AE / BLR / SS  
**KN 678** - 35 - 15



● ● AP1 / CH  
**KN 447** - 62 57 15



● ●  
BLR / AEG / BL  
KN 448    -    46    -    20.4



● ● ● ●  
CP8 / CP10 / SL11 / GD1  
KN 484    -    92    -    100



●  
SS  
KN 496    -    41    -    11



●  
AE  
KN 631    -    36    8.5    30



● ●  
AE / AP  
KN 049    -    63.2    14.8    -



●  
MN  
KN 449    60    -    26    24.5



●  
SSM  
KN 453    48    -    38    12  
 73    -    38    12



●  
SN  
KN 243    42    -    15    14



BR + LT    ●  
BRS  
KN 471    -    63    28    -



●  
SS  
P 8110    -    54    43    10



SS

P 8112	-	62.5	37.5	2.7



NK3

P 8117	-	107	53.5	17



SS

P 8119	38	-	-	20

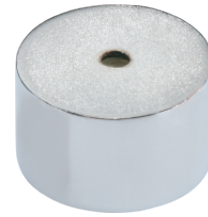

SS

CN 822	34.6	-	-	20



NK2

P 8098	-	54.5	-	11.5
	-	64.5	-	11.5



SS

P 8229	52	-	-	16.5



SSM

P 8230	-	39	29.6	61.2



AE

P 8246	-	26	-	9



MN

P 8248	104	124	89	11.7



AE

ES 901	-	27	32	25



DB

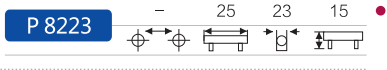

CH

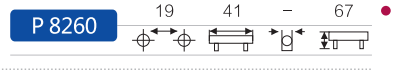

ABL

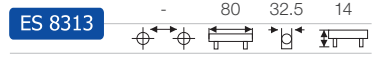

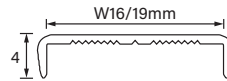

**EDGING**

**Width:** 16 / 19mm  
**Length:** 3.66m  
**Material:** Aluminium  
**UOM:** PC

**Width:** 16mm  
**SRL YAL16.12**

**Width:** 19mm  
**SRL YAL19.12**

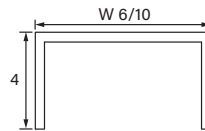
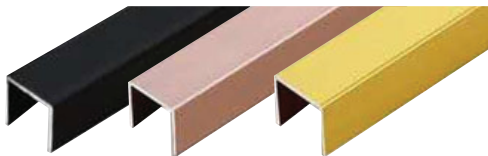

**U SHAPE DECORATIVE STRIP**

**Width:** 6 / 10mm  
**Size:** L3.05m x H4 x T0.8mm  
**Material:** SUS201  
**Finishing:** Mirror Black  
 Mirror Rose Gold  
 Mirror Gold

**Width:** 6mm  
**PP CFU464.305**

**Width:** 10mm  
**PP CFU4104.305**

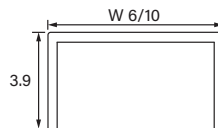
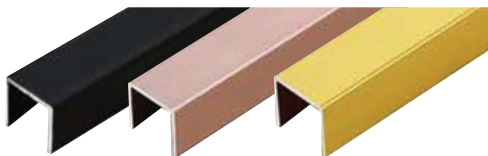

**U SHAPE DECORATIVE STRIP**



**Width:** 6/10mm  
**Length:** L2.7m x H3.9 x T0.6mm  
**Material:** SUS 304 S/Steel  
**Finishing:** Black  
 Rose Gold  
 Gold

**Size:** W6 x H3.9mm  
**PP CY.U6.F**

**Size:** W10 X H3.9mm  
**PP CY.U10.G** -Gold Only

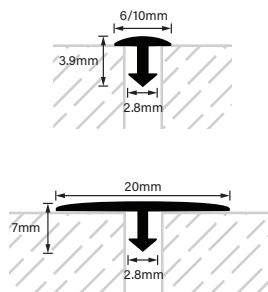
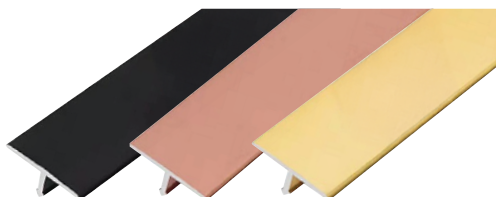

**T SHAPE DECORATIVE STRIP**

**Length:** 2.7m  
**Material:** Aluminium  
**Finishing:** Black  
 Rose Gold  
 Gold

**Size:** W6 x H3.9mm  
**PP CY.T6.F**

**Size:** W10 x H3.9mm  
**PP CY.T10.F**

**Size:** W20 X H7mm  
**PP CY.T20.F**